

LTE: Long Term Evolution

Ramona Pinto

Abstract— Although 3G technologies deliver significantly higher bit rates than 2G technologies, “LTE” (3GPP Long Term Evolution), the next-generation network beyond 3G(B3G) will be enabling fixed to mobile migrations of Internet applications or mobile broadband (Voice over IP (VoIP), video streaming, music downloading, mobile TV and many others applicable) everywhere. OFDM meets the LTE requirement for spectrum flexibility and enables cost-efficient solutions for very wide carriers with high peak rates as it uses large number of narrow sub carriers for multi carriers transmission. OFDM uses a large number of narrow sub-carriers for multi-carrier transmission. LTE networks will also provide the capacity to support an explosion in demand for connectivity from a new generation of consumer devices tailored to those new mobile applications, along with Intelligence at the services edge. LTE capabilities in some cases exceed the targets for peak data rates, cell edge user throughput and spectrum efficiency, as well as VoIP and Multimedia Broadcast Multicast Service (MBMS) performance.

Index Terms — LTE, RF, 3GPP, OFDM, MBMS, SC-FDMA, Wireless

1 INTRODUCTION

Due to fast increasing of data rate requirement by the mobile services, 2Mbps is not enough any more for TDSCDMA in several years. New mobile system to provide high data rate service is expected. As predicted by ITU, the new B3G commercial system should provide 100Mbps~1Gbps data rate service, and the enhanced or evolved 3G should provide 10~50Mbps data rate.

As the B3G is not available until 2010, 3G and WLAN should fulfill the requirements on higher data rate and capacity before 2010. Although WLAN can provide much higher data rate, e.g., 54Mbps by IEEE 802.11a, it only supports indoor deployment and very slow mobility, and the full mobility can only be supported by cellular network.

802.16 can provide up to 76Mbps in 20MHz frequency band, and 802.16e is been modifying to improve its performance on mobility. To be competitive, 3G systems must be enhanced and evolved. Besides the HSDPA, HSUPA, Long Term Evolution (LTE) is being researched and standardized in 3GPP. LTE is the natural evolution of 3GPP GSM and WCDMA networks. It is also an evolution candidate for 3GPP2 CDMA networks. The idea of LTE is to enhance and improve the system performance of 3G with the matured technologies which can be adopted in B3G in several years. The objective of LTE is to provide packetbased high-data-rate service with enhanced coverage, capacity, low latency and low cost.

Discussing about B3G International Mobile Telecommunications (IMT)-2000 introduced global standard for 3G. Systems

beyond IMT-2000 (IMT-Advanced) is set to introduce evolutionary path beyond 3G. Mobile class targets 100 Mbps with high mobility and nomadic/local area class targets 1 Gbps with low mobility. •

3GPP and 3GPP2 are currently developing evolutionary/revolutionary systems beyond 3G.(a) 3GPP Long Term Evolution (LTE) (b)3GPP2 Ultra Mobile Broadband (UMB). IEEE 802.16-based WiMAX is also evolving towards 4G through 802.16m.

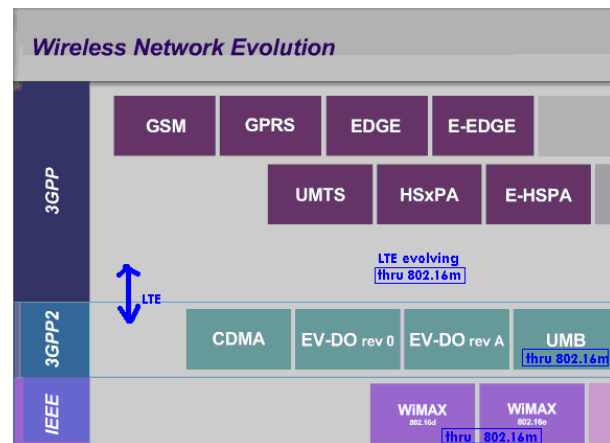

Figure 1: Wireless Network Evolution

2 TECHNICAL REQUIREMENT OF LTE

Specific technical requirements of LTE include:

- Low latency and high throughput**
- Efficient always-on operation, with instantaneous access to network resources**
- Support for real-time and non-real-time applications**
- Co-Existence and Interworking with the 3GPP Radio Access Technology (RAT):** Co-existence in the same geographical area and co-location with UTRAN on adjacent channels. E-UTRAN terminals also supporting UTRAN operations should be able to support measurement of, and

Ramona Pinto, PHD scholar.
This work is supported by Dr. K.L.Sharma, Professor,
Electronics and communication department, Jai Narain Vyas University,
Jodhpur, Rajasthan, 342001, India
Email: Ramona.pinto@hotmail.com

- handover from and to, both 3GPP UTRAN and 3GPP GERAN.
- e. **Further Enhanced Multimedia Broadcast Multicast Service (MBMS):** Similar modulation, coding, multiple access approaches, and UE bandwidth as for a unicast operation. Provision of simultaneous dedicated voice and MBMS services for the end users. Available for paired and unpaired spectrum arrangements.
 - f. **Mobility:** Optimized for low mobile speeds from 0 to 15 kmph. High performance for higher mobile speeds between 15 and 120 kmph. Pan cellular network mobility shall be maintained at speeds. Ranging from 120 kmph to 350 kmph (up to 500 kmph depending on the frequency band).
 - g. **Peak Data Rate:** . An instantaneous downlink peak data rate of 100 Mbps (5 bps/Hz) within a 20 MHz downlink spectrum allocation. An instantaneous uplink peak data rate of 50 Mbps (2.5 bps/Hz) within a 20MHz uplink spectrum allocation).
 - h. **Control-Plane Latency:** Transition time of less than 100 ms from a camped state (idle) to an active state . Transition time of less than 50 ms from a dormant state to an active state.
 - i. **Control-Plane Capacity:** 200 users per cell supported active state for spectrum allocations up to 5 MHz.
 - j. **User-Plane Latency:** Less than 5 ms in an unload condition, such as a single-user with a single data stream, for a small IP packet.
 - k. **User Throughput:** Downlink: Average user throughput per MHz, 3 to 4 times Release 6 HSDPA.. Uplink: Average user throughput per MHz, 2 to 3 times Release 6 Enhanced Uplink.
 - l. **Spectrum Efficiency:** Downlink: In a loaded network, target for spectrum efficiency. (bits/sec/Hz/site), 3 to 4 times Release 6 HSDPA) Uplink: In a loaded network, target for spectrum efficiency (bits/sec/Hz/site), 2 to 3 times Release 6 Enhanced Uplink
 - m. **BANDS:** New 700MHz and 2.6GHz bands that have been sprouting up in spectrum auctions around the globe as of late and with the cooperation of chipset LTE 4G handsets will be able to support bandwidths between 1.4 and 20MHz and the oh-so-exciting 700MHz bands.

3 LTE/SAE(SYSTEM ARCHITECTURE EVOLUTION)

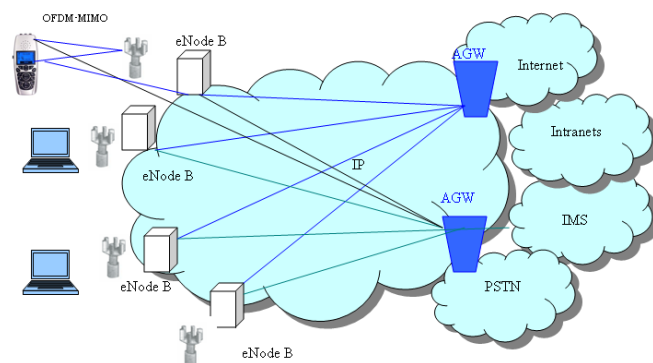

Figure 2: LTE/SAE architecture

A typical LTE/SAE network will have two types of network elements supporting the user and control planes. > The first is the new enhanced base station, so called “Evolved NodeB (eNodeB)” per 3GPP standards. This enhanced BTS provides the LTE air interface and performs radio resource management for the evolved access system. > The second is the new Access GateWay (AGW). The AGW provides termination of the LTE bearer. It also acts as a mobility anchor point for the user plane. It implements key logical functions including MME (Mobility Management Entity) for the Control Plane and SAE PDN GW (System Architecture Evolution Packet Data Network GateWay) for the User Plane. These functions may be split into separate physical nodes, depending on the vendor-specific implementation. Comparing the functional breakdown with existing 3G architecture:

A. Radio Network elements functions,

Such as Radio Network Controller (RNC), are distributed between the AGW and the enhanced BTS (eNodeB). Submit your manuscript electronically for review.

B. Core Network elements functions,

Such as SGSN and GGSN or PDSN (Packet Data Serving Node) and routers are distributed mostly towards the AGW. LTE standards continue to evolve, exact functional split between the eNodeB and the AGW is under test.

C. All-IP flat networks

Using IP networking as the foundation for service delivery provides maximum flexibility, decouples the user and control planes to simplify the network and improve scalability, and allows the wealth of existing IETF standards to be leveraged. Specific requirements include:

Optimal routing of traffic, IP-based transport, Seamless mobility (intra- and inter- Radio Access Technologies) & Simplification of the network

4 OFDM TRANSMISSION IN LTE

In the downlink, OFDM is selected to efficiently meet E-UTRA performance requirements. With OFDM, it is straightforward to exploit frequency selectivity of the multi-path channel with low complexity receivers. This allows frequency selective in addition to frequency diverse scheduling and one cell reuse of available bandwidth.

Furthermore, due to its frequency domain nature, OFDM enables flexible bandwidth operation with low complexity. Smart antenna technologies are also easier to support with OFDM, since each sub-carrier becomes flat faded and the antenna weights can be optimized on a per sub-carrier (or block of sub-carriers) basis.

In addition, OFDM enables broadcast services on a synchronized single frequency network (SFN) with appropriate cyclic prefix design. This allows broadcast signals from different cells to combine over the air, thus significantly increasing the received signal power and supportable data rates for broadcast services.

To provide great operational flexibility, E-UTRA physical layer specifications are bandwidth agnostic and designed to accommodate up to 20 MHz system bandwidth. Table 2 provides the downlink sub-frame numerology for different spectrum allocations.

OFDM performance in multipath conditions, Phase noise immunity, Required Power Amplifier Backoff for regulatory conformance were studied as follows by calculating the Packet Error Rate (PER) as a function of the received Signal to Noise Ratio (SNR) for various multipath conditions.

In regards to Phase noise immunity problem is omnipresent in all high-efficiency microwave communication systems. This section analyzes the effects of phase noise on OFDM performance.

Consider an OFDM system degraded by an oscillator phase noise. Let us denote by

T - the OFDM symbol duration

$f_u = 1/T$ - the intercarrier spacing

$P(\omega)$ - the power spectral density of the phase noise process in rad^2/Hz .

The phase noise effect can be broken into two phenomena:

1. Common Phase Error (CPE)
2. Intercarrier Carrier Interference (ICI).

The effect of CPE is that all subcarriers are rotated by a common random angle. The Noise/Signal ratio resulting from CPE effect is given by:

$$\left(\frac{N}{S}\right)_{CPE} = \int_{-\infty}^{\infty} \sin^2(f) W(f) df \quad (a)$$

The CPE can be corrected, almost completely, by using pilot subcarriers. Hence it will not be considered here.

The ICI effects are due to the loss of orthogonality incurred by the phase noise process. The noise /signal ratio caused by ICI is given by:

$$\left(\frac{N}{S}\right)_{ICI} = \int_{-\infty}^{\infty} P_{\phi}(f) W(f) df \quad (b)$$

Where the $W(f)$ is given by

$$W(f) = \sum_{n=0} \text{sinc}^2\left(\frac{f}{f_u} + n\right) \quad (c)$$

To evaluate eq(b) we assume use of a simple one pole model for the phase noise process. While being somewhat simplified, this model still captures the important effects of phase noise related degradation.

The phase noise PSD is therefore given by:

$$P_{\phi}(f) = \frac{\Phi_0^2}{\pi f_c} \frac{1}{1 + (f/f_c)^2} \quad (d)$$

is the integrated RMS power of the phase noise process and f_c is the 3dB corner.

Combining (b) (c)(d) we get:

$$\left(\frac{N}{S}\right)_{ICI} = \frac{2\Phi_0^2}{\pi} \frac{f_u}{f_c} \int_{-\infty}^{\infty} \frac{1}{1 + (f/f_c)^2} \sum_{n \neq 1} \text{sinc}^2(f - n) df \quad (e)$$

For a specific oscillator operating at 5.7GHz, following parameters can be obtained

$$\Phi_0^2 = -35\text{dBc}$$

$$f_c = 10\text{KHz}$$

The single-sided PSD of this particular phase noise process is shown in Figure below:

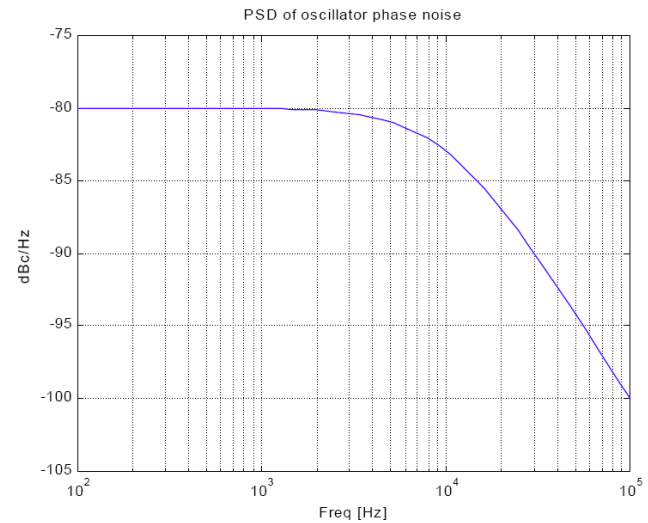

Figure 3: PSD of phase noise process

These values were used to produce Figure below, where the resulting ICI induced SNR is plotted as a function of the carrier spacing f_u . We should note that above analysis assumed that there is only one non-ideal oscillator in the system. However, all communication systems employ a transmitting side and a receiving side. Thus, if both sides employ the same oscillator, the results will be worse by 3-dBs.

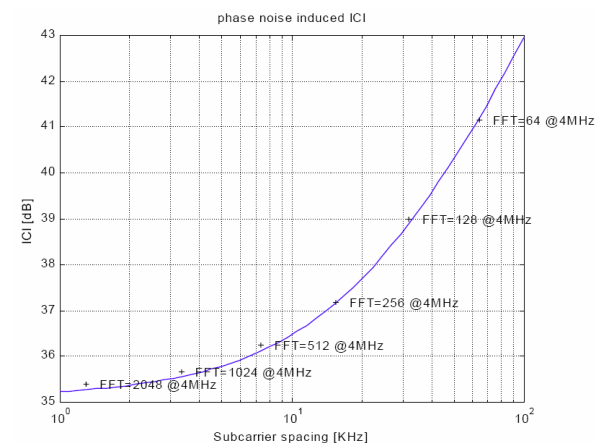

Figure 4: ICI induced SNR vs. Subcarrier spacing

Thus for this we can conclude that the ICI induced SNR is lower bounded by the integrated phase noise of the oscillator. For typical oscillators, this value is about -35dBc. This may be sufficient QAM64 operation. With high subcarrier spacing the resulting SNR is even higher. The OFDM parameters include: 512 FFT with raised-cosine window, 4Ms/sec complex sampling rate, 75% active subcarriers. The PA backoff, required to

meet regulatory requirements, is about 8-10dB for the OFDM case, and 6-8 dB for the QAM16 single-carrier case. Sub-frames with one of two cyclic prefix (CP) durations may be time-domain multiplexed, with the shorter designed for unicast transmission and the longer designed for larger cells or broadcast SFN transmission. The useful symbol duration is constant across all bandwidths. The 15 kHz sub-carrier spacing is large enough to avoid degradation from phase noise and Doppler (250km/h at 2.6 GHz) with 64QAM modulation.

SC-FDMA Uplink Transmission

In the uplink, Single-Carrier Frequency Division Multiple Access (SC-FDMA) is selected to efficiently meet E-UTRA performance requirements. SC-FDMA has many similarities to OFDM, chief among them for the uplink that frequency domain orthogonality is maintained among intra-cell users to manage the amount of interference generated at the base. SC-FDMA also has a low power amplifier de-rating requirement, thereby conserving battery life or extending range. The baseline SC-FDMA signal is DFT-Spread OFDM (DFTSOFDM) as shown in Figure 5.

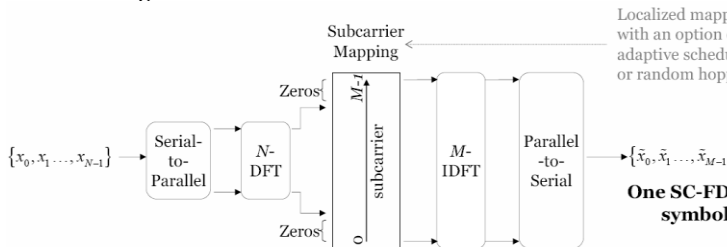

Figure 5: BLOCK DIAGRAM for DFT-SOFDM

Because channels differ in size in different countries, the 802.16 standard supports all of the various channel sizes, ranging from 1.25 MHz to 20 MHz. Keeping the sub channel spacing fixed by changing the FFT size based on channel size or bandwidth provides better signal quality. Doppler shift of a moving body (amongst other aspects) affects signal quality if the sub channel spacing is not maintained at a fixed size. A user traveling through a cell might receive signal through 128 FFT or 512 FFT depending on factors such as channel size.

The only difference from OFDM is the addition of the M-point FFT (DFT) in the figure which “spreads” M symbols onto the M sub-carriers selected by the symbol to sub-carrier mapping. The selected subcarriers must also be either adjacent to or evenly spaced to maintain the low PA power de-rating. The signal is considered single carrier as the first M-point FFT and the larger N-point IFFT cancel each other resulting in a single carrier signal in the time domain. The receiver can use simple frequency domain equalization.

The definition of the (N-point) discrete Fourier transform (DFT) is:

$$X_p[k] = \sum_{n=0}^{N-1} x_p[n] e^{-j(2\pi/N)kn} \quad \text{(DFT) (f)}$$

and the (N-point) inverse discrete Fourier transform (IDFT):

$$x_p[n] = \frac{1}{N} \sum_{k=0}^{N-1} X_p[k] e^{j(2\pi/N)kn} \quad \text{(IDFT) (g)}$$

A natural consequence of this method is that it allows us to generate carriers that are orthogonal. The members of an orthogonal set are linearly independent.

Consider a data sequence (d0, d1, d2, ..., dN-1), where each dn is a complex number dn=an+jbn. (an, bn=± 1 for QPSK, an, bn=± 1, ± 3 for 16QAM, ...)

$$D_k = \sum_{n=0}^{N-1} d_n e^{-j(2\pi nk/N)} = \sum_{n=0}^{N-1} d_n e^{-j2\pi f_n t_k} \quad k=0,1,2, \dots, N-1 \quad \text{(h)}$$

where fn=n/(ND T), tk=kD t and D t is an arbitrarily chosen symbol duration of the serial data sequence dn. The real part of the vector D has components

$$Y_k = \text{Re}\{D_k\} = \sum_{n=0}^{N-1} [(a_n \cos(2\pi f_n t_k) + b_n \sin(2\pi f_n t_k))] \quad k=0,1, \dots, N-1 \quad \text{(i)}$$

If these components are applied to a low-pass filter at time intervals D t, a signal is obtained that closely approximates the frequency division multiplexed signal

$$y(t) = \sum_{n=0}^{N-1} [(a_n \cos(2\pi f_n t_k) + b_n \sin(2\pi f_n t_k))] \quad 0 \leq t \leq N\Delta t \quad \text{(j)}$$

An advantage for DFT-SOFDM as a SC-FDMA technique is that the numerology can match the OFDM downlink, with excellent spectral occupancy due to the IFFT providing pulse shaping of the signal.

The OFDM numerology provides for an additional vacant DC sub-carrier to simplify some receiver architectures; a vacant sub-carrier cannot be used with DFT-SOFDM without affecting the low PA de-rating property of DFT-SOFDM. Orthogonality of reference signals is obtained via frequency domain multiplexing onto a distinct set of sub-carriers.

The RS sequence length is equal to the number of sub-carriers in the resource blocks. For allocation sizes of 3 resource blocks or more, the demodulation RS sequence is generated by truncation of ZC (Zadoff-Chu) sequences. For smaller allocations, computer generated sequences will be used.

5 FRAME STRUCTURE

The E-UTRA frame structure is shown in Figure 7 where one 10ms radio frame is comprised of ten 1ms sub-frames. For FDD, uplink and downlink transmissions are separated in the frequency domain. For TDD, a sub-frame is either allocated to downlink or uplink transmission. Note that for TDD, sub-frame 0 and sub-frame 5 are always allocated for downlink transmission. An alternative frame structure exists in E-UTRA to provide compatibility with LCR-TDD. Note that the basic time unit is given by $T_s = 1 / (15000 \times 2048)$ seconds.

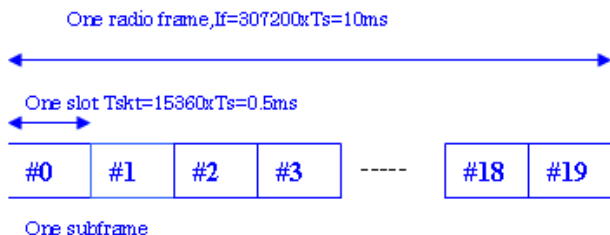

Figure 6: E-UTRA (TDD) frame structure

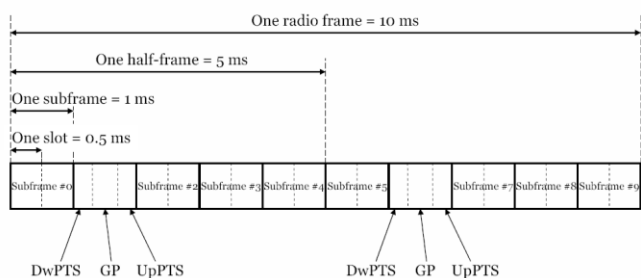

Figure 7: E-UTRA (FDD) frame structure

Control-plane protocol stack Band Arrangement. E-UTRA is designed to operate in the frequency bands defined in table 1. The requirements are defined for 1.4, 3, 5, 10, 15 and 20MHz bandwidth with a specific configuration in terms of number of resource blocks. (6, 15, 25, 50, 75 and 100 RB). Figure 8 shows the relation between the total channel bandwidth, the transmission bandwidth configuration, i.e the number of resource blocks. The channel raster is 100 KHz (the center frequency must be a multiple of 100 KHz). To support transmission in paired and unpaired spectrum, two duplex modes are supported: Frequency Division Duplex (FDD), supporting full duplex and half duplex operation, and Time Division Duplex (TDD).

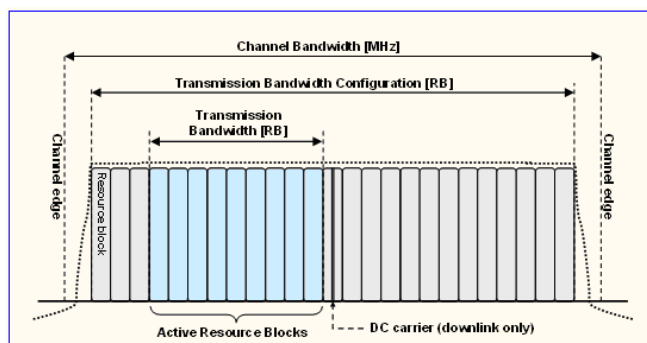

Figure 8: Relation of channel BW and Tx BW.

Transmission scheme:

The multiple access schemes for the LTE physical layer is based on Orthogonal Frequency Division Multiple Access (OFDM) with a Cyclic Prefix (CP) in the downlink and a Single Carrier Frequency Division Multiple Access (SC-FDMA) with CP in the uplink.

OFDMA technique is particularly suited for frequency selective channel and high data rate. It transforms a wideband frequency selective channel into a set of parallel flat fading narrowband channels, thanks to CP. This ideally, allows the receiver to perform a low complex equalization process in frequency domain, i.e 1 tap scalar equalization.

The baseband signal representing a downlink physical channel is defined in terms following:

- scrambling of coded bits in each of the code words to be transmitted on a physical channel
- modulation of scrambled bits to generate complex-valued modulation symbols
- mapping of the complex-valued modulation symbols onto one or several transmission layers
- precoding of the complex-valued modulation symbols on each layer for transmission on the antenna ports
- mapping of complex-valued modulation symbols for each antenna port to resource elements
- generation of complex-valued time-domain OFDM signal for each antenna port

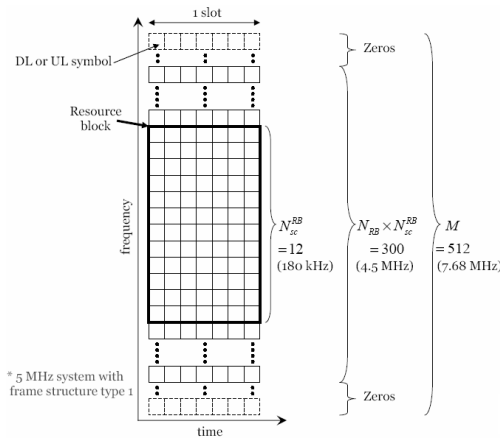

Figure 9: Bandwidth configuration

Configuration	N_{symbol}
Normal CP	7
Extended CP	6
Extended CP ($\Delta f = 7.5 \text{ kHz}$) [†]	3

Configuration	CP length $N_{\text{CP},l}$ [samples]
Normal CP	160 ($\approx 5.21 \mu\text{s}$) for $l = 0$ 144 ($\approx 4.69 \mu\text{s}$) for $l = 1, 2, \dots, 6$
Extended CP	512 ($\approx 16.67 \mu\text{s}$) for $l = 0, 1, \dots, 5$
Extended CP ($\Delta f = 7.5 \text{ kHz}$) [†]	1024 ($\approx 33.33 \mu\text{s}$) for $l = 0, 1, 2$

Figure 10: Length of CP

MIMO & LTE

Spectrum efficiency can be improved by MIMO. MIMO is a very exciting technology to improve the spectrum efficiency. Combining OFDM with MIMO, the frequency selective fading MIMO channel can be separated into many flat fading MIMO subchannels, and thus the decoding of the MIMO channel can be processed as a flat fading channel on every subcarrier and the adaptive modulation on subcarrier basis can be adapted conveniently.

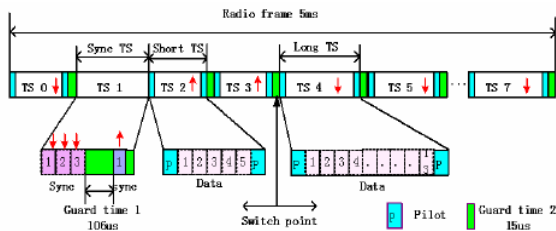

Figure 11: Frame structure of LTE based TDD

OFDM splits the information into multiple narrowband sub-carriers, allowing each of them to carry a portion of the information at a lower bit rate, which makes OFDM a very robust modulation, particularly in multipath scenarios, like urban areas. MIMO technology creates several spatial paths on the air interface between the network and the subscriber; so these paths can carry the same or different streams of information, allows an increase in either the coverage (due to higher Signal to Noise Ratio (SNR) at the receiver) or the user data throughput.

Radio Interface

The figure below shows the protocol stack for the user-plane, where PDCP, RLC and MAC sublayers (terminated in eNB on the network side) perform header compression, ciphering, scheduling, ARQ and HARQ.

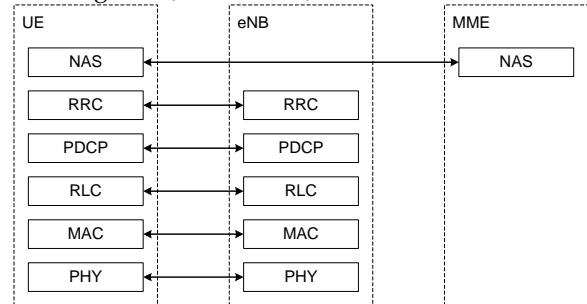

Figure 12: User-plane protocol stack

The figure below shows the protocol stack for the control-plane. The NAS control protocol is mentioned for information only and is part of UE -EPC communication. The PDCP sublayer performs e.g. ciphering and integrity protection, RLC and MAC sublayers perform the same functions as for the user plane. The RRC performs broadcast, paging, RRC connection management, Radio Bearer control, Mobility functions, UE measurement reporting and control.

6 FREQUENCY REUSE

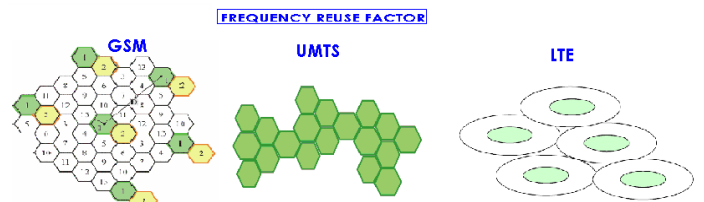

Figure 13: Frequency Reuse Factor

Fractional Re-Use: Users near the base station re-use the same frequencies (OFDM sub-carriers), whereas users at the cell boarder are allocated to sub-carriers in a co-ordinated manner between base stations to minimize interference. Its an advantage towards complex frequency designing for the network.

The throughputs of an OFDM system with 2 antennas at transmitter and 4 antennas at receiver are shown as Figure 4. The bandwidth is 20MHz, and the data subcarriers are 832 of 1024. The RMS of the channel time delay is 50ns. Based on the frame structure in of Figure 5, the peak data rate of 16QAM modulation without channel coding is more than 70Mbps with ideal channel estimation. With higher modulation order and more antennas at the transmitter and receiver, higher data rate more than 100Mbps can be obtained in 20MHz bandwidth.

Although the channel coding may decrease the peak data rate, it can guarantee the reliability of the transmission and decrease the SNR required.

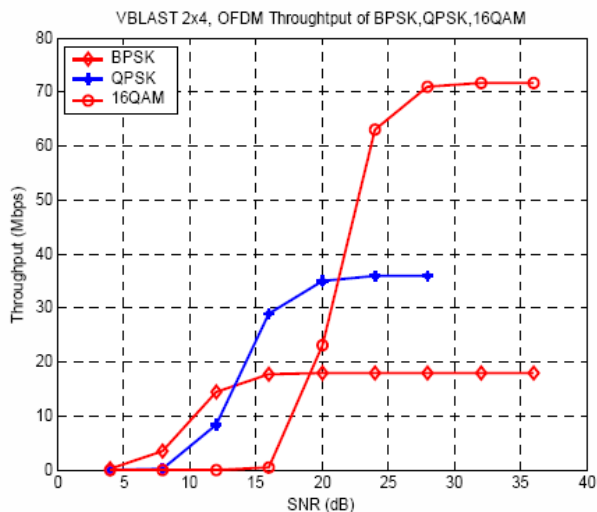

Figure 14: The throughput of the VBLAST OFDM system

Thus LTE TDD can offer 50~100Mbps data rate in both uplink and downlink respectively with 20MHz bandwidth.

7 CONCLUSION

By introducing new technologies step by step, e.g., MIMO, OFDM, cooperative relaying, Ad Hoc and scalable bandwidth, evolved TD-SCDMA system can provide higher data rate service with low latency, low cost, improved coverage and capacity. The 3G LTE continues to study the network evolution from the perspective of providing an enhanced end-user-experience through higher data rates 160 Mbps & more, low latency & low cost optimized network deployments embracing technologies for 3GPP (GSM/EDGE and UMTS/HSPA) & 3GPP2 (CDMA and EV-DO) operators. The 3G LTE has commitments from some major industry players and in the coming few years, the technology world will witness a radical evolution of 3G including HSPA as well as the physical layer. With expected data rates in excess of 160Mbps and very low latency, LTE will provide significant improvements to the user experience. LTE's Evolved Packet Core is IP centric and technology agnostic, will allow operators to provide common applications and services across other fixed and wireless access technologies. LTE, with its added capacity and simplified architecture will deliver cost effective voice and data services and will also benefit from high levels of spectrum flexibility, making it very well suited for deployments by operators in both developed and emerging markets. The day is not far when estimation of 32 million LTE network subscribers will be established by 2013, after its commercial launch if tested & implemented all fine by 2010.

REFERENCES

- [1] U. Varshney and R. Jain, "Issues in emerging 4G wireless networks," *IEEE Computer*, vol. 34, pp. 94-96, Jun. 2001.
- [2] H. Ekström et al., "Technical Solutions for the 3G Long-Term Evolution," *IEEE Commun. Mag.*, vol. 44, no. 3, March 2006, pp.38-45
- [3] Mobile Broadband: The Global evolution of UMTS/HSPA; 3GPP Release 7 and beyond. UTRA-UTRAN Long Term Evolution (LTE) and 3GPP System Architecture Evolution (SAE)-
<http://www.3gpp.org/Highlights/LTE/LTE.htm>
- [4] 'Feasibility Study of Evolved UTRA and UTRAN', Dahlman, Parkvall, Skold and Beming, 3G Evolution: HSPA and LTE for Mobile Broadband, Academic Press, Oxford, UK, 2007
- [5] ZHANG Ping, TAO Xiaofeng, ZHANG Jianhua, et al, "The Visions from FuTURE Beyond 3G TDD", *IEEE Communication Magazine*, January, 2005.
- [6] 3GPP LTE- Spec
<http://www.3gpp.org/ftp/Specs/html-info/36-series.htm>
<http://www.3gpp.org/ftp/Specs/html-info/25814.htm> (old).
- [7] 3G Americas, "Mobile Broadband: The Global Evolution of UMTS/HSPA - 3GPP Release 7 and Beyond" available at http://www.3gamericas.org/pdfs/UMTS_Rel7_Beyond_Dec2006.pdf, <http://www.LTEwatch.com>
- [8] G. G. Savo, "Advanced Wireless Communications 4G Technologies," WILEY, pp. 3, 2004.